



TECHNICAL INSTRUCTION HAC10-002 Rev. N/C, Jan 13, 2010

**TECHNICAL INSTRUCTION  
HAC10-002 Rev. N/C, Jan. 13, 2010**

**INSTRUCTIONS FOR CONTINUED AIRWORTHINESS**

**JA161T6046-3A Spring & JA161T6047-9A Spool Assembly  
INSTALLED ON  
Boeing 767 Aircraft**

**UNCONTROLLED COPY**

Verify latest approved revision at <http://ipc.heico.com>



## TECHNICAL INSTRUCTION HAC10-002 Rev. N/C, Jan 13, 2010

### 1. Introduction

This HEICO Aerospace Technical Instruction (TI) defines the Instructions for Continued Airworthiness for PMA part numbers JA161T6046-3A Spring and JA161T6047-9A Spool Assembly used on the Boeing 767 main landing gear lock struts. The Springs and Spool assemblies are interchangeable with TCH PN's 161T6046-3 and 161T6047-9, but only as sets as described below. The PMA parts have a design modification to improve fatigue life and eliminate parts from fracturing on the aircraft.

This ICA affects data presented in Boeing publications:

- Boeing 767 Component Maintenance Manual Section 32 (all)

The data contained in this Technical Instruction is FAA Approved. Contact HEICO Customer Support for assistance or questions regarding this Technical Instruction at:

- Telephone: 954-961-9800 (8AM to 5PM EST)
- FAX: 954-987-7585
- Email: [cs@heico.com](mailto:cs@heico.com)



## TECHNICAL INSTRUCTION HAC10-002 Rev. N/C, Jan 13, 2010

### **2. Eligibility, Installation and Replacement:**

The Instructions for Continued Airworthiness presently acceptable to the FAA for P/N 161T6046-3 and 161T6047-9 are applicable to JA161T6046-3A and JA161T6047-9A with exception of the following:

2.1 - JA161T6046-3A Spring and JA161T6047-9A Spool Assembly may be used in any location to replace 161T6046-3 Spring and 161T6047-9 Spool Assembly, on both Side and Drag Brace Lock Struts.

2.2 - JA161T6046-3A Springs must be used with two JA161T6047-9A Spool Assemblies as spring hook size diameter is smaller than that of 161T6046-3. Similarly, JA161T6047-9A Spool Assemblies must not be used with 161T6046-3 Springs.

2.3 - JA161T6046-3A/JA161T6047-9A Spring/Spool sets may be used on the same Side or Drag Strut Brace as (along side of) 161T6046-3/161T6047-9 Spring/Spool sets.

2.4 - JA161T6046-3A Springs do not need to be replaced after 5,000 cycles as suggested for 161T6046-3.

2.5 - Installation tools used for 161T6046-3/161T6047-9 Spring/Spool sets must be modified as shown below.

### TECHNICAL INSTRUCTION HAC10-002 Rev. N/C, Jan 13, 2010

2.5 - (cont'd) Modify Spring Extender Tool A32099-77, Detail A32099-42 as shown. Dimensions in mm (inches):

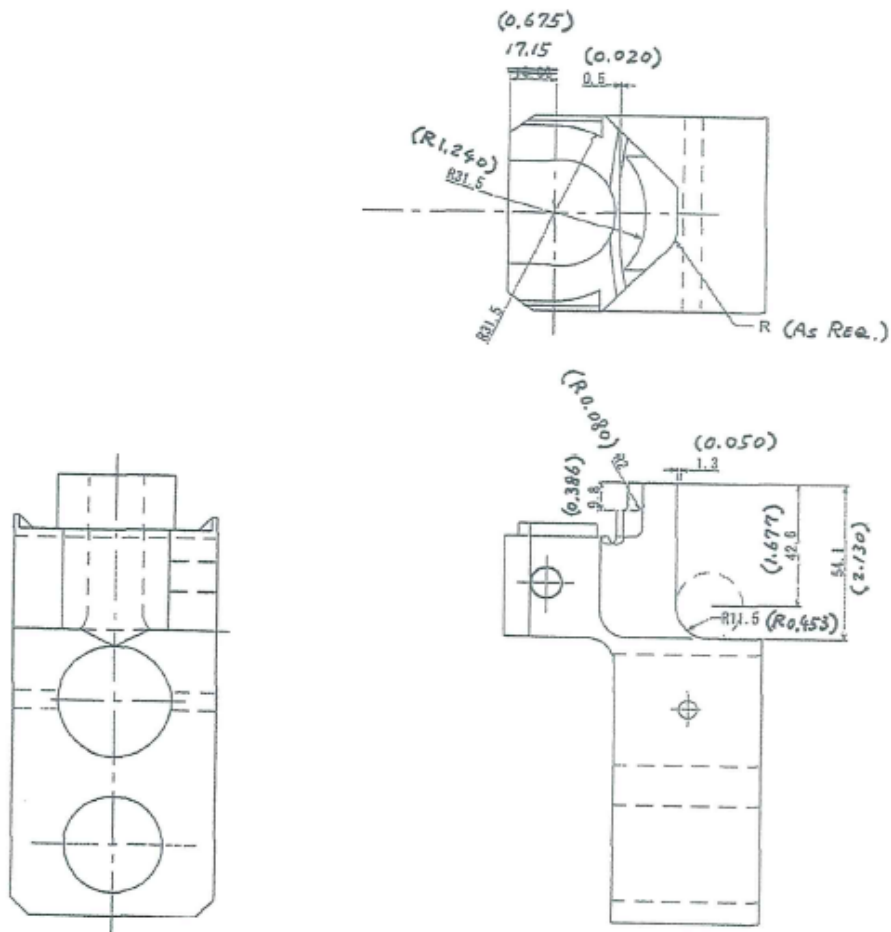

**TECHNICAL INSTRUCTION HAC10-002 Rev. N/C, Jan 13, 2010**

2.5 – (cont'd) Modify detail A32099-43 as shown. Dimensions in mm (inches):

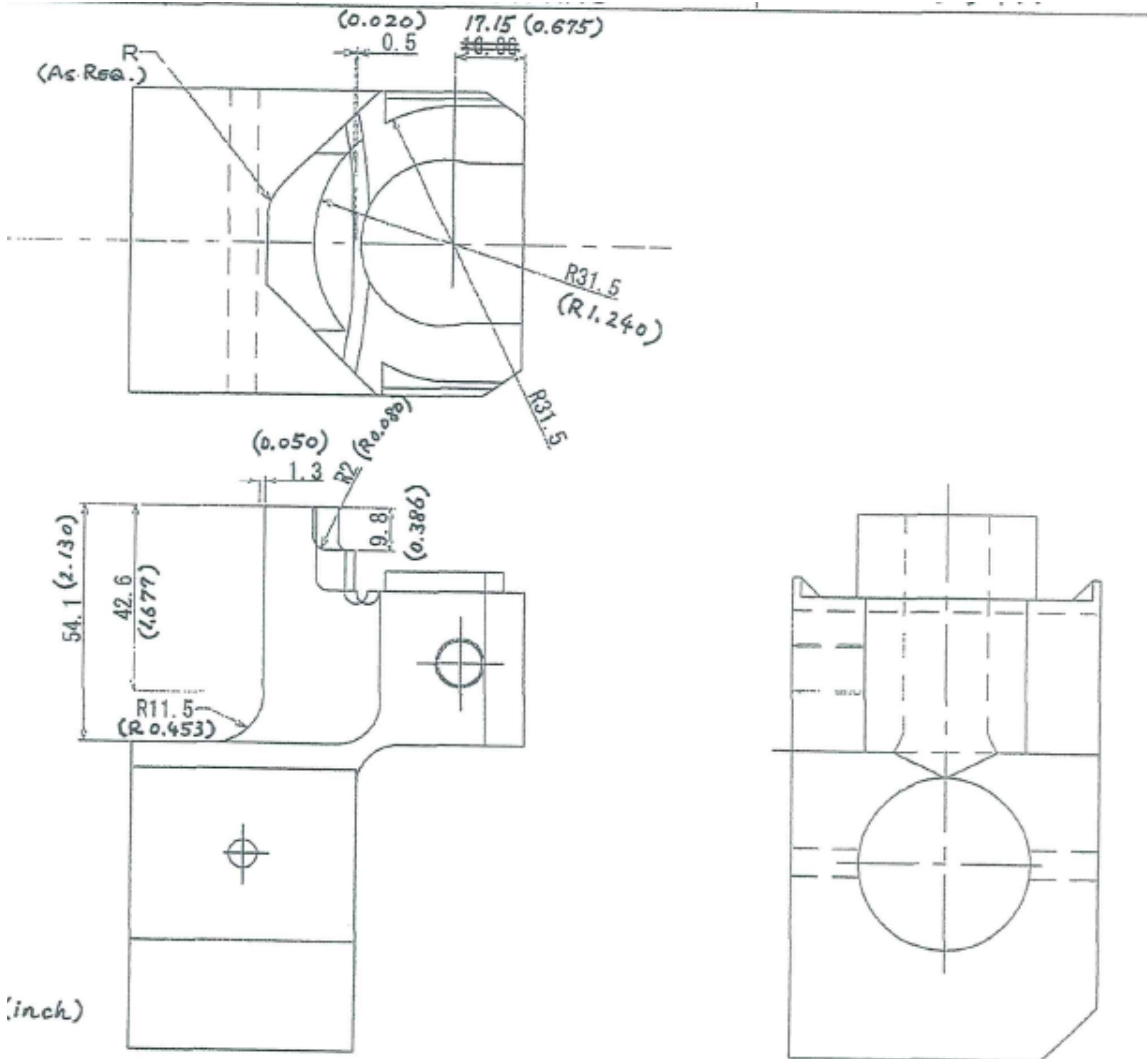

**3. Material Information**

This document will be maintained and the latest approved revision posted on the HEICO web site at <http://ipc.heico.com>.

**4. Revision and Approval History**

Initial Release – Jan 13, 2010